

# 50W ZigBee CCT LED Driver(constant current)

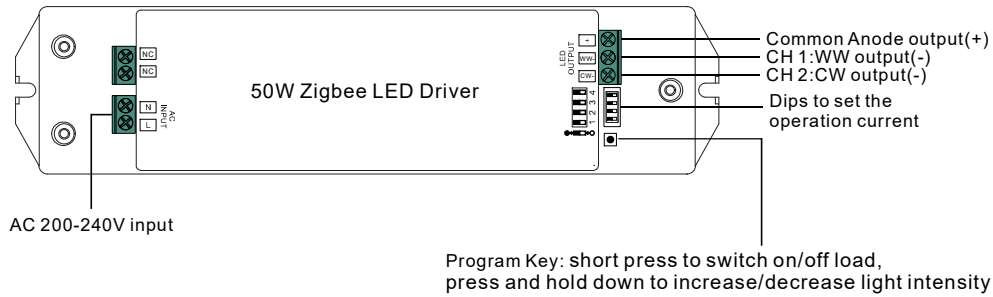

**Important:** Read All Instructions Prior to Installation

## Function introduction



## Product Data

Output	LED Channel	2							
	Selectable Current	850mA	900mA	950mA	1000mA	1050mA	1100mA	1150mA	1200mA
	DC Voltage Range	8-52V	8-52V	8-52V	8-50V	8-47V	8-45V	8-43V	8-41V
	Selectable Current	1250mA	1300mA	1350mA	1400mA	1450mA	1500mA		
	DC Voltage Range	8-40V	8-38V	8-37V	8-35V	8-34V	8-33V		
	Current Tolerance	±5%							
	Rated Power	Max. 50W							
Input	Voltage Range	200-240V AC							
	Frequency Range	50/60Hz							
	Power Factor (Typ.)	> 0.97							
	Total Harmonic Distortion	THD ≤ 8% (@ full load / 230VAC)							
	Efficiency (Typ.)	87% @ 230VAC full load							
	AC Current (Typ.)	0.27A @ 230VAC							
	Inrush Current (Typ.)	COLD START Max. 8A at 230VAC							
	Leakage Current	< 0.5mA /230VAC							
Control	Dimming Interface	Zigbee 3.0							
	Dimming Range	0.1%-100%							
	Dimming Method	Amplitude dimming (PWM dimming under 1%)							

Protection	Short Circuit	Yes, recovers automatically after fault condition is removed
	Over Voltage	Yes, recovers automatically after fault condition is removed
	Over Temperature	Yes, recovers automatically after fault condition is removed
Environment	Working Temp.	-20°C ~ +45°C
	Max. Case Temp.	75°C (Ta= "45°C")
	Working Humidity	10% ~ 95% RH non-condensing
	Storage Temp. & Humidity	-40°C ~ +80°C, 10% ~ 95% RH
Safety & EMC	Safety Standards	ENEC EN61347-1, EN61347-2-13 approved
	Withstand Voltage	I/P-O/P: 3.75KVAC
	Isolation Resistance	I/P-O/P: 100M Ohms / 500VDC / 25°C / 70% RH
	EMC Emission	EN55015, EN61000-3-2, EN61000-3-3
	EMC Immunity	EN61547, EN61000-4-2,3,4,5,6,8,11
Others	MTBF	191300H, MIL-HDBK-217F @ 230VAC at full load and 25°C ambient temperature
	Dimension	210*50*32mm (L*W*H)

## Dips to set the operation current



	1	2	3	4		1	2	3	4
850mA	○	○	○	○		●	○	○	○
900mA	○	○	○	●		●	○	○	○
950mA	○	○	○	○		●	○	○	○
1000mA	○	○	○	○		●	○	○	○
1050mA	○	○	○	○		●	○	○	○
1100mA	○	○	○	○		●	○	○	○
1150mA	○	○	○	○		●	○	○	○
1200mA	○	○	○	○		●	○	○	○
						●	○	○	○
						●	○	○	○
						●	○	○	○
						●	○	○	○
						●	○	○	○
						●	○	○	○

- Dimmable LED driver for tunable white, ZigBee device based on ZigBee 3.0 protocol
- Max. output power 50W total, 2 channels 850-1500mA constant current output
- Class II power supply, full isolated plastic case
- Built-in active PFC function, high power factor and efficiency
- Amplitude dimming (PWM dimming under 1%)
- Deep and smooth dimming to 0.1%, flicker free
- Standby power consumption less than 0.5W, meet latest ERP requirements
- Enables to control ON/OFF, light intensity and CCT LED lights
- ZigBee end device that supports Touchlink commissioning
- Can directly pair to a compatible ZigBee remote via Touchlink
- Supports find and bind mode to bind a ZigBee remote
- Supports zigbee green power and can bind max. 20 zigbee green power switches
- Compatible with universal ZigBee gateway products
- Compatible with universal CCT ZigBee remotes
- Waterproof grade: IP20, suitable for indoor LED lighting applications
- 5 years warranty

## Safety & Warnings

- DO NOT install with power applied to device.
- DO NOT set operation current with power applied to the device.
- DO NOT expose the device to moisture.

## Operation

1. Do wiring according to connection diagram correctly.

2. This ZigBee device is a wireless receiver that communicates with a variety of ZigBee compatible systems. This receiver receives and is controlled by wireless radio signals from the compatible ZigBee system.

### 3. Zigbee Network Pairing through Coordinator or Hub (Added to a Zigbee Network)

**Step 1:** Remove the device from previous zigbee network if it has already been added to, otherwise pairing will fail. Please refer to the part "Factory Reset Manually".

**Step 2:** From your ZigBee Controller or hub interface, choose to add lighting device and enter Pairing mode as instructed by the controller.

**Step 3:** Re-power on the device to set it into network pairing mode (connected light flashes twice slowly), 15 seconds timeout, repeat the operation.

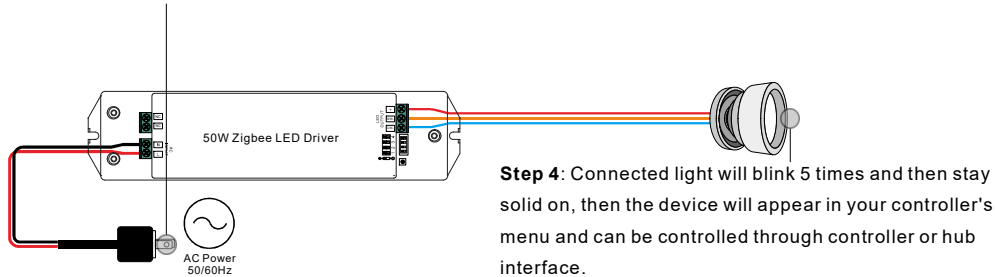

### 4. TouchLink to a Zigbee Remote

**Step 1: Method 1:** Short press "Prog." button 4 times (or re-power on the device 4 times) to start Touchlink commissioning immediately, 180S timeout, repeat the operation.

**Method 2:** Re-power on the device, Touchlink commissioning will start after 15S if it's not added to a zigbee network, 165S timeout. Or start immediately if it's already added to a network, 180S timeout. Once timeout, repeat the operation.

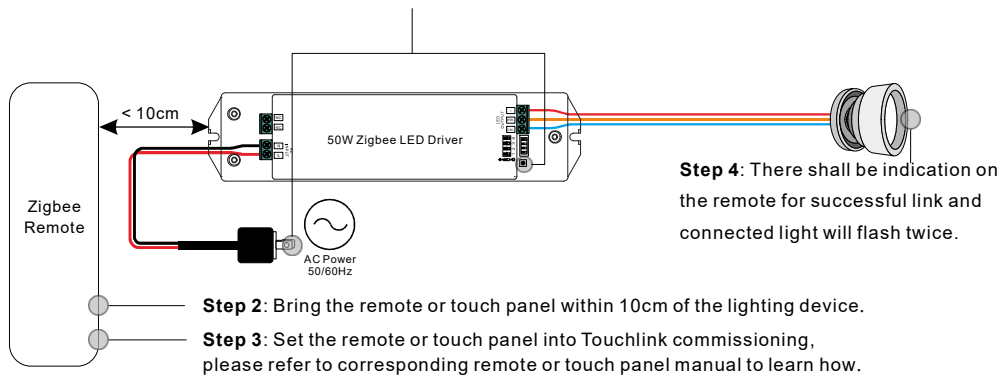

- Note:**
- 1) Directly TouchLink (both not added to a ZigBee network), each device can link with 1 remote.
  - 2) TouchLink after both added to a ZigBee network, each device can link with max. 30 remotes.
  - 3) To control by both gateway and remote, add remote and device to network first then TouchLink.
  - 4) After TouchLink, the device can be controlled by the linked remotes.

### 5. Removed from a Zigbee Network through Coordinator or Hub Interface

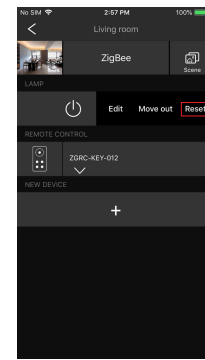

From your ZigBee controller or hub interface, choose to delete or reset the lighting device as instructed. The connected light blinks 3 times to indicate successful reset.

### 6. Factory Reset Manually

**Step 1:** Short press "Prog." key for 5 times continuously or re-power on the device for 5 times continuously if the "Prog." key is not accessible.

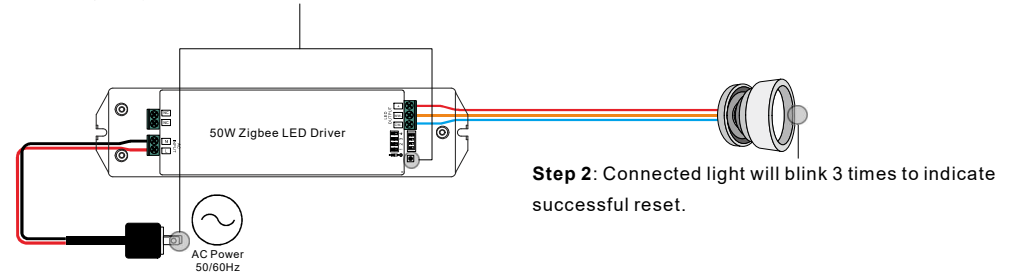

- Note:**
- 1) If the device is already at factory default setting, there is no indication when factory reset again.
  - 2) All configuration parameters will be reset after the device is reset or removed from the network.

### 7. Factory Reset through a Zigbee Remote (Touch Reset)

**Note:** Make sure the device already added to a network, the remote added to the same one or not added to any network.

**Step 1:** Re-power on the device to start TouchLink Commissioning, 180 seconds timeout, repeat the operation.

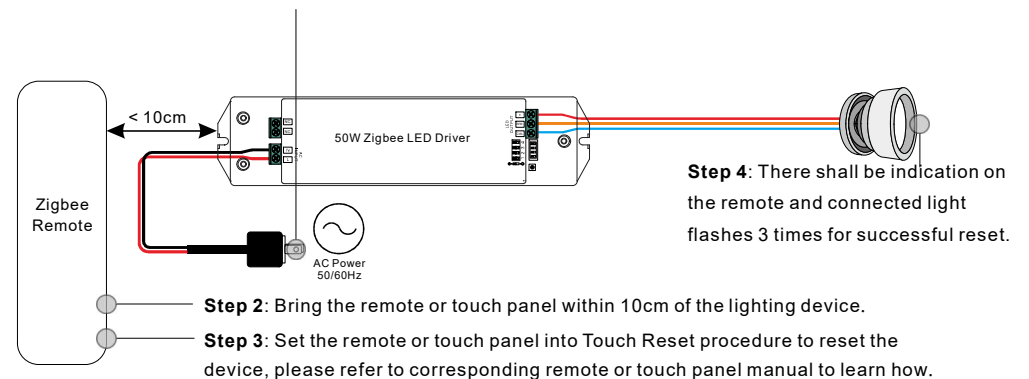

## 8. Find and Bind Mode

**Step 1:** Short press “Prog.” button 3 times (Or re-power on the device (initiator node) 3 times) to start Find and Bind mode (connected light flashes slowly) to find and bind target node, 180 seconds timeout, repeat the operation.

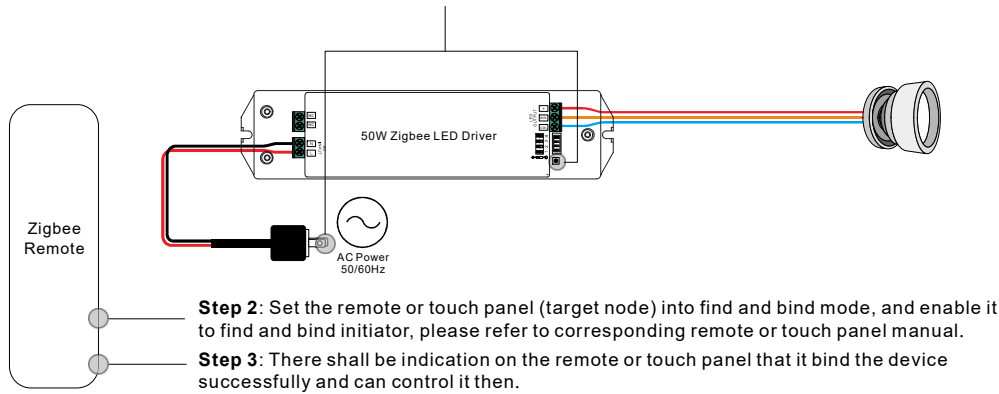

## 9. Learning to a Zigbee Green Power Switch

**Step 1:** Short press “Prog.” button 4 times (Or re-power on the device 4 times) to start Learning to GP switch mode (connected light flashes twice), 180 seconds timeout, repeat the operation.

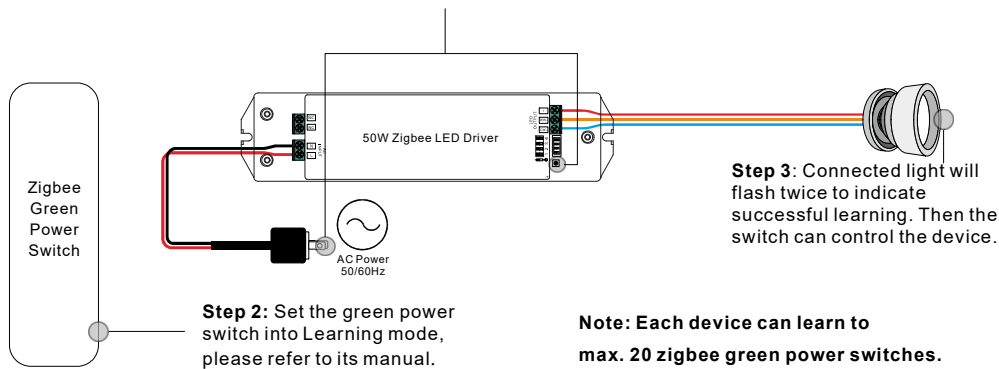

## 10. Delete Learning to a Zigbee Green Power Switch

**Step 1:** Short press “Prog.” button 3 times (Or re-power on the device 3 times) to start delete Learning to GP switch mode (connected light flashes slowly), 180 seconds timeout, repeat the operation.

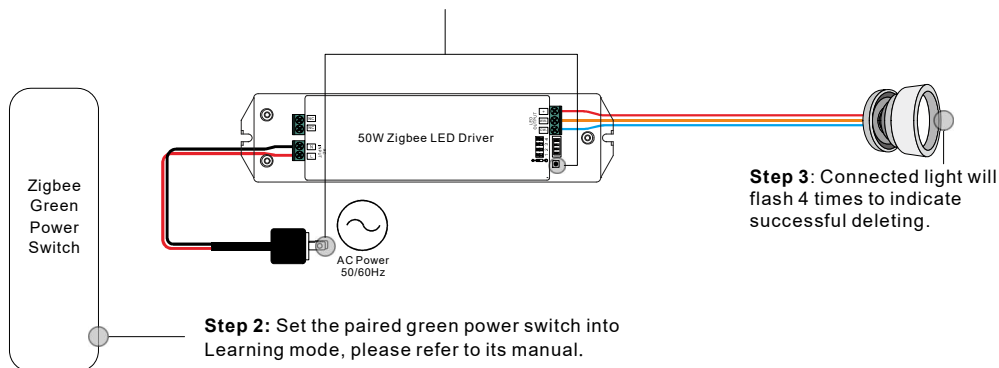

## 11. Setup a Zigbee Network & Add Other Devices to the Network (No Coordinator Required)

**Step 1:** Short press “Prog.” button 4 times (Or re-power on the device 4 times) to enable the device to setup a zigbee network (connected light flashes twice) to discover and add other devices, 180 seconds timeout, repeat the operation.

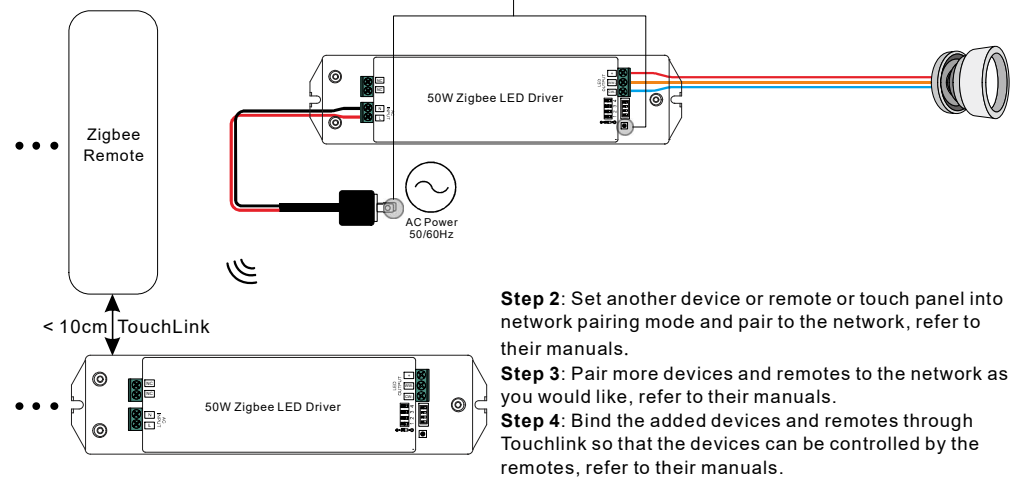

**Note:** 1) Each added device can link and be controlled by max. 30 added remotes.

2) Each added remote can link and control max. 30 added devices.

## 12. ZigBee Clusters the device supports are as follows:

### Input Clusters

- 0x0000: Basic
- 0x0003: Identify
- 0x0004: Groups
- 0x0005: Scenes
- 0x0006: On/off
- 0x0008: Level Control
- 0x0300: Color Control
- 0x0b05: Diagnostics

### Output Clusters

- 0x0019: OTA

## 13. OTA

The device supports firmware updating through OTA, and will acquire new firmware from zigbee controller or hub every 10 minutes automatically.

## Wiring Diagram

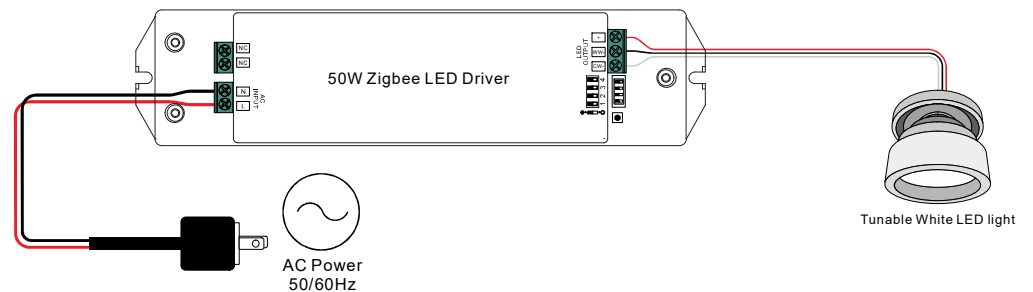

**Product Dimension**

